

baridi

55cm 60/40 Fridge Freezer with Adjustable Thermostat, 254L Capacity White/Black

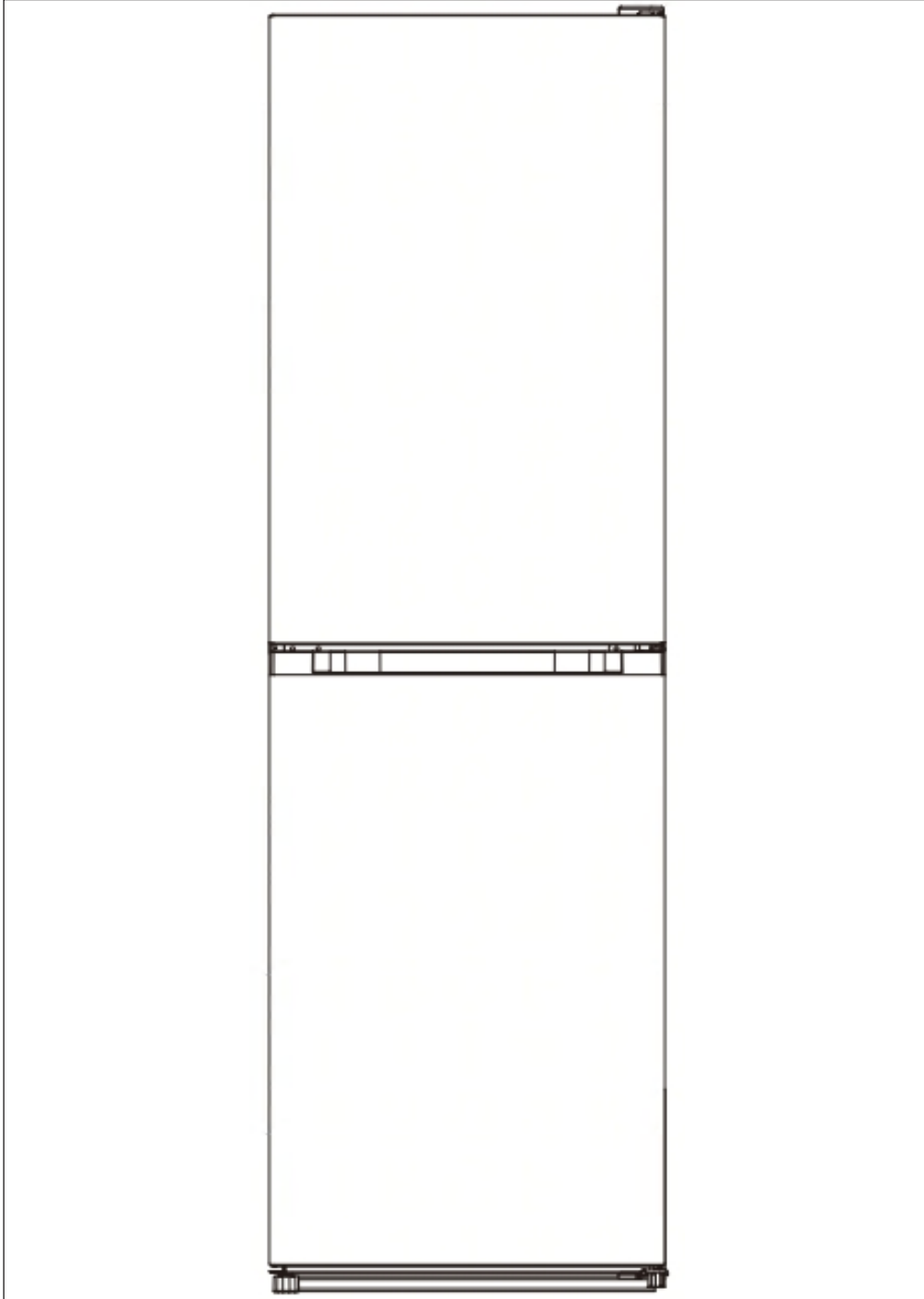

Models: DH328 DH329

Thank you for purchasing a Baridi product. Manufactured to a high standard, this product will, if used according to these instructions, and properly maintained, give you years of trouble free performance.

Important Information

Please read these instructions carefully. Note the safe operational requirements, warnings & cautions. Use the product correctly and with care for the purpose for which it is intended. Failure to do so may cause damage and/or personal injury and will invalidate the warranty. Keep these instructions safe for future use.



Refer to instructions



Indoor use only



Warning flammable material

• ELECTRICAL SAFETY

- **WARNING!** It is the user's responsibility to check the following:
- Check all electrical equipment and appliances to ensure that they are safe before using.
- Inspect power supply leads, plugs and all electrical connections for wear and damage.
- Ensure that the insulation on all cables and on the appliance is safe before connecting it to the power supply.
- **DO NOT** use worn or damaged cables, plugs or connectors.
- Ensure that any faulty item is repaired or replaced immediately by a Sealey qualified technician.
- If the cable or plug is damaged during use, switch off the electricity supply and remove from use.
- If the supply cord is damaged, it must be replaced by the manufacturer, its service agent or similarly qualified persons in order to avoid a hazard.
- Sealey recommend that an **RCD** (Residual Current Device) is used with all electrical products.
- **Important:** Ensure that the voltage rating on the appliance suits the power supply to be used and that the plug is fitted with the correct fuse.
- **DO NOT** pull or carry the appliance by the power cable.
- **DO NOT** pull the plug from the socket by the cable.

• GENERAL SAFETY

- Children from age 8 years and above, persons with reduced physical, sensory, or mental capabilities those with lack of experience and knowledge can use the appliance, if they have been given supervision or instruction concerning use of the appliance in a safe way to understand the hazards involved.
- Children aged from 3 to 8 years are allowed to load and unload refrigeration devices.
- Children shall **NOT** play with the appliance.
- Cleaning and user maintenance on the appliance shall not be made by children without supervision.
- The appliance shall be disconnected from its power source during service and when replacing parts and, if that the removal of the plug is foreseen, it shall be clearly indicated that the removal of the plug has to be such that an operator can check from any of the points to which he has access that the plug remains removed.
- This refrigeration appliance is not intended to be used as a built-in appliance.
- This refrigerant appliance is intended to be used at ambient temperatures ranging from 16°C to 38°C.
- **DO NOT** store explosive substances such as aerosol cans with a flammable propellant in this appliance.
- This appliance is intended to be used in household and similar applications such as:
 - – staff kitchen areas in shops, offices and other working environments
 - – farm houses and by clients in hotels, motels and other residential type environments
 - – bed and breakfast type environments
 - – catering and similar non-retail applications.
- The appliance shall not be exposed to rain.
- If the refrigerating appliance is left empty for long periods, switch off, defrost, clean, dry, and leave the door open to prevent mould developing within the appliance.
- **WARNING!** When positioning the appliance, ensure the supply cord is not trapped or damaged.
- **WARNING! DO NOT** locate multiple portable socket-outlets or portable power supplies at the rear of the appliance.
- **WARNING! DO NOT** use mechanical devices or other means to accelerate the defrosting process, other than those recommended by the manufacturer.
- **WARNING! DO NOT** damage the refrigerant circuit.
- **WARNING! DO NOT** use electrical appliances inside the food storage compartments of the appliance, unless they are of the type recommended by the manufacturer.
- To avoid contamination of food, please respect the following instructions:
 - – Opening the door for long periods can cause a significant increase of the temperature in the compartments of the appliance.
 - – Clean regularly surfaces that can come in contact with food and accessible drainage systems.
 - – Clean water tanks if they have not been used for 48h. Flush the water system connected to a water supply if water has not been drawn for 5 days.
 - – Store raw meat and fish in suitable containers in the refrigerator, so that it is not in contact with or drip onto other food.
 - – If the refrigerating appliance is left empty for long periods, switch off, defrost, clean, dry, and leave the door open to prevent mould developing within the appliance.
- **WARNING!** Keep room ventilation openings in the appliance environment clear of obstruction.

PRODUCT FEATURES

No.	Description	No.	Description
1	Control panel	5	Freezer Drawers
2	Glass shelves	6	Adjusting Feet
3	Crisper Cover	7	Bottle Frames
4	Crisper		

• DOOR REVERSAL INSTRUCTIONS

- Make sure that your refrigerator is unplugged.
- Carefully remove the hole covers and screws, then lift the top cover. Unscrew the three fasteners securing the upper hinge to the door, and remove the hinge. (fig.2).
- Remove the refrigerator compartment door from the cabinet.
- Remove the screws securing the lower hinge to the right side of the cabinet, then detach the hinge. Next, remove the adjustable foot from the left side. (fig.3).
- Remove the washer and nut securing the pin shaft to the right hole of the lower hinge, then withdraw the shaft. (fig.4).
- Insert the pin shaft into the left hole of the lower hinge, then secure it using the washer and nut. (fig.5).
- Fit the freezer compartment door into position. (fig.6).
- Relocate the door bushing from the top right to the top left side of the freezer door. Then, transfer the hole cover from the left side to the right. (fig.7).
- Install the refrigerator compartment door. (fig.8).
- Relocate the door bushing from the top right to the top left side of the door, and move the left hole cover to the right side.
- Remove the hole cover from the top left side of the cabinet and install it on the top right side. (fig.9).
- Secure the upper hinge to the top left side of the cabinet using the three previously removed screws. Before tightening, ensure the top of the door is level with the cabinet and the rubber gasket forms a proper seal.
- Fit the hinge cover over the hinge on the top left side of the cabinet.
- Ensure the rubber gaskets are making a good seal with the cabinet all the way around the doors before tightening the hinge screws.

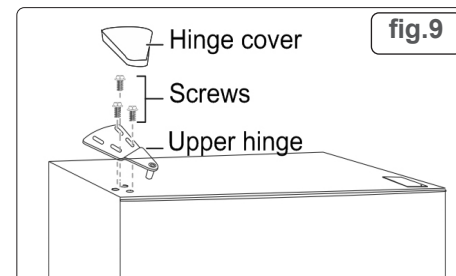
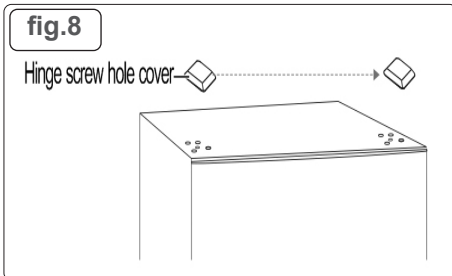
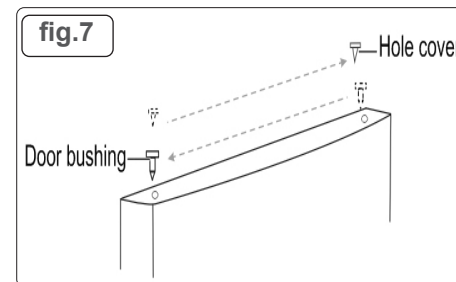
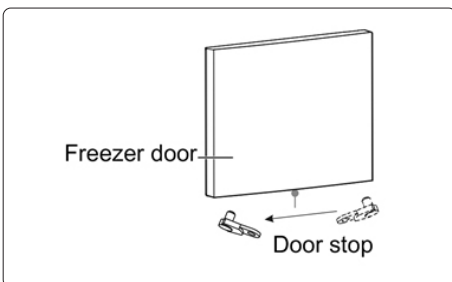
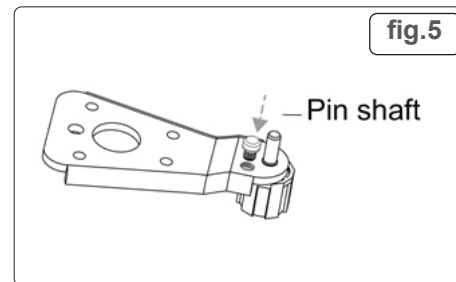
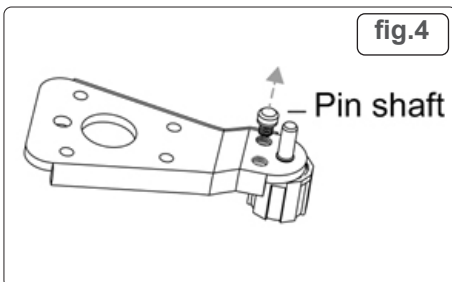
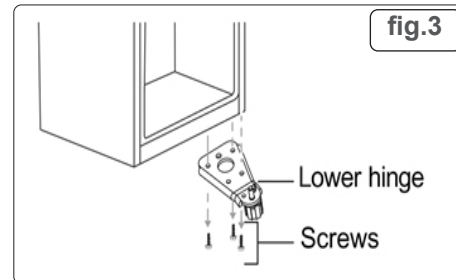
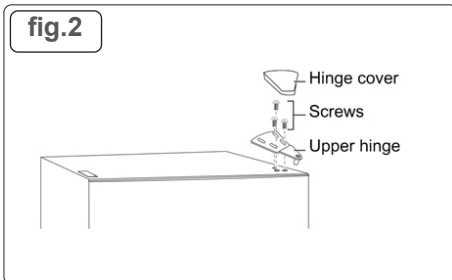
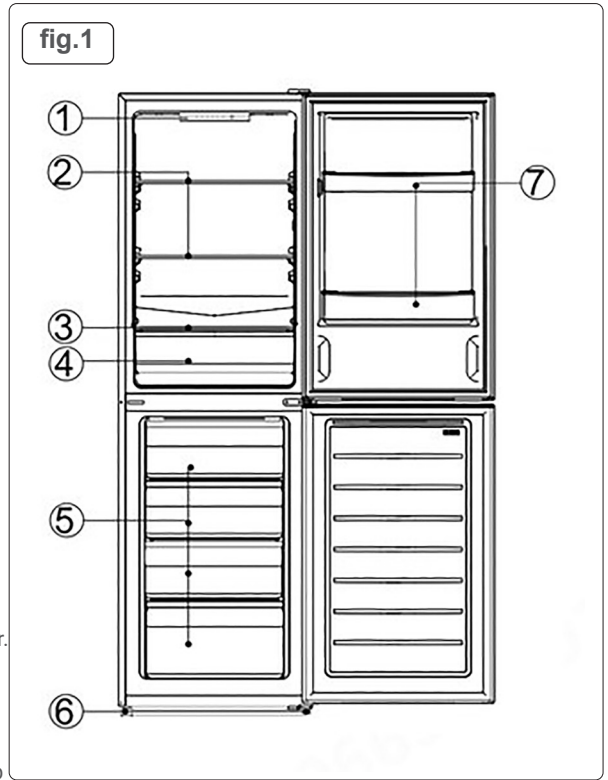

SPECIFICATION

MODEL NO	DH328	DH329
Capacity	254L (154L Fridge, 100L Freezer)	254L (154L Fridge, 100L Freezer)
Climate Class	N/ST	N/ST
Colour	White	Black
Defrost Method	Manual	Manual
Door Style	Reversible	Reversible
Energy Rating	E	E
Energy Efficiency Class	E	E
Foaming Gas	Cyclopentane	Cyclopentane
Dimensions (W x D x H)	540 x 550 x 1760mm	540 x 550 x 1760mm
Number of Shelves	3 (Fridge), 4 Drawers (Freezer)	3 (Fridge), 4 Drawers (Freezer)
Nett Weight	51kg	51kg
Power Cable Length	2.35m	2.35m
Rated Current	0.5A	0.5A
Refrigerant	R600a (52g)	R600a (52g)
Temperature Range	Fridge 0 to 10°C Freezer-16 to -24°C	Fridge 0 to 10°C Freezer-16 to -24°C
Type	Freestanding	Freestanding
Supply	230V~50Hz	230V~50Hz

• INSTALLATION LOCATION

• VENTILATION CONDITIONS

- The position you select for the freezer installation should be well-ventilated and not near a heat source such as cooker, and away from direct sunlight, thus guaranteeing the refrigeration effect while saving energy consumption. **DO NOT** locate the freezer in the damp place, so as to prevent the freezer from rusting.
- Please allow at least the free space requirements shown below when installing the unit.

W	D	H	A	B	C (°)	E	F
540	550	1760	910	1055	130 ±5	50	100

- NOTE:** Fig.10, Fig.11 illustrate the space required around the unit installation.

• LEVEL GROUND

- Place the freezer on the solid and flat ground (floor) to keep it stable or else it will vibrate and be noisy. When the freezer is placed on materials such as carpet, straw mat, polyvinyl chloride, solid backing plates should be fitted underneath the unit to prevent damage to the flooring.

- NOTE:** Unobstructed ventilation shall be maintained around the appliance or in an embedded structure.

• PREPARATIONS FOR USE

• STANDING TIME

- After the freezer is properly installed and well cleaned, **DO NOT** switch it on immediately. Leave the freezer to stand for more than 1 hour to allow gas to settle, thus ensuring its normal operation.

- Cleaning

- Wipe the inside of the freezer with a dry, clean soft cloth.

• POWER-ON

- Insert the plug into the solid socket to start the compressor. After 1 hour, open the freezer door, if the temperature inside the freezer compartment drops, it indicates the refrigeration system is working normally.

• STORAGE OF FOOD

- After the freezer runs for a period of time, the internal temperature of the freezer will be automatically controlled according to the user's temperature setting. After the freezer is fully cooled, put in your food, which usually need 2~3 hours to be fully cooled. In summer, when the temperature is high, it takes more than 4 hours for the foods to be fully cooled. (Open the door as little as possible before the internal temperature cools down).
- Setting up the freezer may cause noise or image disturbance on your mobile phone, fixed-line telephone, radio receiver, television surrounding it. Keep the freezer as far away from these items as possible.

• OPERATION

- PRE CHECKS - STANDING TIME DO NOT** turn on for 4 hours. Ensure unit is not connected to the power source.
- Clean the freezer with lukewarm water and detergent and wipe dry.

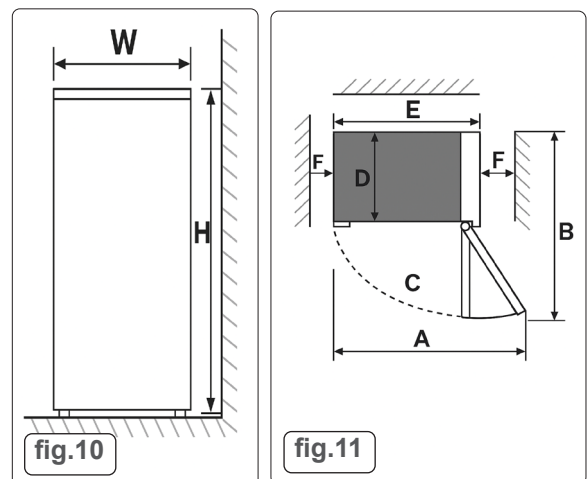

- **NOTE:** Electrical components should be cleaned with a dry cloth.
- Set the thermostat knob to "2" and plug the freezer into the wall outlet. The compressor will begin to run.
- Check, after 30 minutes of operation, to ensure that the freezer is cold.



• TEMPERATURE CONTROL

- The temperature of the refrigerator is controlled by the control panel mounted in the fridge compartment. (See fig.1.1, fig.12).
- After the freezer is in place it needs to be left for 4 hours. This allows time for the coolant to settle.
- The refrigerator temperature settings cycle as following: 5/4/3/2/1/**FASTCOOL**/5.
- The mode "3" is recommended and mode "5" is not recommended to avoid frozen food
- You can set the 'fast cool' function to quickly cool or freeze foods. The fastcool function will exit automatically after 26 hours, or can be disabled manually.
- **Note:** If the indicator light '5' or '3' or '1' flickers, it indicates that the refrigerator has broken down. Please contact the after-sales personnel for on-site service as soon as possible.

• INSTRUCTIONS FOR FOOD STORAGE

- **DO NOT** overload the freezer with food. Keep enough space between foods; if too close, the cold air flow will be blocked, thus affecting the refrigeration performance. **DO NOT** store excessive or overweight foods, to avoid the shelf from being bent. When storing the foods, keep a distance away from the inner wall; and **DO NOT** place the water-rich foods too close to the freezer rear wall, lest they get frozen on the inner wall.

• FOOD STORAGE LOCATION

- Due to the cold air circulation in the refrigerator, the temperature of each area in the refrigerator is different, so different kinds of food should be placed in different areas.
- The fresh food compartment is suitable for the storage of such foods as need not to be frozen, the cooked food, beer, eggs, some condiments that need cold preservation, milk, fruit juice, etc. The crisper box is suitable for the preservation of vegetables, fruits, etc.
- The freezer compartment is suitable for the storage of ice cream, frozen food and the foods to be preserved for a long time.

• USE OF THE FRESH FOOD COMPARTMENT

- Set the temperature of the fresh food storage compartment between 2 °C ~ 8 °C, and store the foods that are intended for short-term storage, or to be eaten at any time in the fresh food compartment.
- Fridge shelf: When removing the shelf, lift it up first, and then pull it out; and when installing the shelf, place it into position before putting it down. (For the two-section shelf, push the first section to the rear end, and then pull the second section out). Keep the shelf rear flange upward, to prevent foods from contact the liner wall. When taking out or putting in the shelf, hold it firmly, and handle with care to avoid damage.
- Crisper box: Pull out the crisper box for access to food. After using or cleaning the cover plate of the crisper box, be sure to put it back onto the crisper, so that the internal temperature of the crisper box will not be affected.

• FREEZER MODE

- Long-term storage of foods: The freezer compartment, where the temperature is generally controlled below -18°C, is suitable for the preservation of foods for a long term, but the shelf life indicated on the food packages should be abided by.
- Freezer Drawers designed for storing frozen food. For large cuts of meat or fish, divide them into smaller portions, wrap each separately in freezer-safe bags, and arrange them evenly in the drawer.
- Allow the hot foods to cool down to the room temperature before putting them in the freezer compartment.
- **DO NOT** place glass containers filled with liquid or sealed cans containing liquid in the freezer compartment, as they may burst due to expansion when the liquid freezes.
- Divide the food into appropriately small portions
- Pack the food up before freezing it, and the packing bag used should be dry, in case the packing bags are frozen together. Foods should be packed or covered by such suitable materials as are firm, tasteless, impervious to air and water, non-toxic and pollution-free, to avoid cross-contamination and transfer of odour.

• CAUTIONS FOR FOOD STORAGE

- Clean the foods and wipe them dry before storing them inside the refrigerator. Before foods are put in the refrigerator, it is advisable to seal them up, so as to prevent water evaporation to keep fresh fruits and vegetables on one hand, and prevent taint of odor on the other hand.
- **DO NOT** put too many or too much weight of foods inside the refrigerator. Keep enough space between foods; if too close, the cold air flow will be blocked, thus affecting the refrigeration effect. **DO NOT** store excessive or overweight foods, to avoid the shelf from being crushed. When storing the foods, keep a distance away from the inner wall; and **DO NOT** place the water-rich foods too close to the fridge rear wall, lest they get frozen on the inner wall.

• CATEGORIZED STORAGE OF FOODS

- Foods should be stored by category, with the foods you eat every day placed in front of the shelf, so that the door open duration can be shortened and food spoilage due to expiration can be avoided.
- **Energy-saving tips:** Allow the hot food to cool down to the room temperature before putting it in the refrigerator. Put the frozen food in the fresh food compartment to thaw, using the low temperature of the frozen food to cool the fresh food, thus saving energy.

• STORAGE OF FRUITS AND VEGETABLES

- In the case of refrigerating appliances with chill compartment, some types of fresh vegetables and fruits are sensitive to cold and therefore are not suitable for storage in this kind of compartment.

• TIPS FOR SHOPPING FROZEN FOODS

- When you are buying frozen food, look at the storage guidelines on the packaging. You will be able to store each item of frozen food for the period shown against the star rating. This is usually the period stated as "Best to use them before x", found on the front or rear of the packaging.
- Check the temperature of the frozen food cabinet in the shop where you buy the frozen foods.
- Make sure the frozen food package is in perfect condition.
- Always buy frozen products last on your shopping trip or visit to the supermarket.
- Try to keep frozen food together whilst shopping and on the journey home, as this will help to keep the food cooler.
- **DO NOT** buy frozen food unless you can freeze it straight away. Special insulated bags can be bought from most supermarkets and hardware shops. These keep the frozen foods cold longer.
- For some foods, thawing before cooking is unnecessary. Vegetables and pasta can be added directly to boiling water or steam cooked. Frozen

sauces and soups can be put into a saucepan and heated gently until thawed.

- Use quality food and handle it as little as possible. When foods are frozen in small quantities, it will take less time for them to freeze up and thaw.
- Estimate the amount of foods to be frozen up. When freezing large amounts of fresh food, adjust the temperature control knob to the low mode, with the freezer temperature lowered.

• MAINTENANCE AND CLEANING

- **WARNING!** Before cleaning, unplug the power plug first. **DO NOT** plug in or pull plug out the plug with wet hands because of the risk of electric shock and injury. **DO NOT** spill water directly on the freezer to avoid rust, electricity shock and accidents. **DO NOT** stretch your hands into the bottom of the freezer, since you might be scratched by sharp metal corners.
- **WARNING!** The appliance shall be disconnected from its power source during service and when replacing parts and, if that the removal of the plug is foreseen, it shall be clearly indicated that the removal of the plug has to be such that an operator can check from any of the points to which he has access that the plug remains removed.
- Cleaning and user maintenance on the appliance shall not be made by children without supervision.
- **INTERNAL CLEANING AND EXTERNAL CLEANING**
- The food residuals in the freezer are liable to produce bad odour, so the freezer must be cleaned regularly.
- Remove all removable internal fittings and clean them with a soft towel or sponge dipped in warm water or neutral detergent.
- Clear off the dust accumulated on the rear panel and side plates of the freezer often.
- After using detergent, be sure to rinse it with clean water, and then wipe it dry.
- **DO NOT** use bristle brush, steel wire brush, detergent, soap powder, alkaline detergent, benzene, gasoline, acid, hot water and other corrosive or soluble items to cleanse the cabinet surface, door gasket, plastic decorative parts, etc, so as to avoid damage.
- Carefully wipe dry the door gasket, clean the groove using a wooden implement wrapped with cotton string.
- After the cleaning, fix the four corners of the door gasket first, and then embed it segment by segment into the door groove.

• CHANGING THE LAMP

- The refrigerator uses an **LED** lamp for internal lighting, offering low energy consumption and a long service life. If any issues arise, please contact an authorised Baridi stockist or a qualified electrician. For safety reasons, **LED** lamp replacement must only be carried out by someone who is electrically qualified or authorised to perform such repairs.

• INTERRUPTION OF POWER SUPPLY OR FAILURE OF THE REFRIGERATING SYSTEM

- Take care of the frozen foods in the event of an extended non-running of the refrigerating appliance (such as interruption of power supply or failure of the refrigerating system).
- Try to open the freezer door as infrequently as possible, in this way food can be safely and freshly kept for hours even in hot summer.
- If you get the power outage notice in advance.
- Adjust the thermostat knob to the high mode an hour in advance, so that foods get fully frozen (**DO NOT** store new food during this time). Restore the temperature mode to the original setting when power supply becomes normal in a timely manner.
- You can also make ice with a watertight container, and put it in the upper part of the freezer, so as to extend the time for fresh food to be stored.
- **NOTE:** Once the freezer is used, use it continuously; and under normal circumstance, **DO NOT** stop its use, so as not to affect the service life.

• DEFROSTING

- After a period of use, a thin layer of frost will be formed on the freezer compartment inner walls surface which may affect the refrigeration effect if exceeding 5mm in thickness. In such case, you need to gently scrape the frost off using a wooden/plastic ice scraper rather than a metal or sharp hardware. Frost needs to be cleared off every 3 months or so, and if the drawers and access of foods are affected by frosting, make sure to remove the frost in a timely manner.
- **FOLLOW THE FOLLOWING STEPS TO DEFROST**
- Take out the frozen foods, shut off the mains power supply, open the freezer door, and gently remove the frosts from the inner wall with an ice scraper. To speed up the thawing process, you are suggested to place a bowl of hot water inside the freezer, and when the solid ice frosts become loose, use an ice scraper to scrape them off and then take them out.
- After defrosting, clean the freezer inside and switch on the power supply.
- **NOTE:** If the appliance will not be used for an extended period, disconnect it from the power supply, remove all food, clean thoroughly, and leave the door slightly open to prevent unpleasant odours.

• SAFETY-CHECK AFTER MAINTENANCE

- Is the power cord broken or damaged?
- Is the power plug firmly inserted into the socket?
- Is the power plug abnormally overheated?
- **NOTE:** The risk of electric shock or fire may arise if the power cord or plug is damaged or contaminated. In the event of any irregularities, immediately disconnect the power supply and contact the authorised Sealey stockist..

• HOW TO DISASSEMBLE THE PARTS

- **SHELVES**
- Hold one end of the shelf, and lift it up while pulling it outwards.
- **FLIP DOWN COVER**
- Keep the flip cover in the vertical direction, align it with the rotating shaft opening on the right side, and pull it outward to remove it.
- During use of the freezer, **DO NOT** close the door when the flip cover is opened, to avoid damaging the freezer door.

• END OF LIFE DISPOSAL

- Recycle unwanted packaging materials. When this product is no longer required, or has reached the end of its useful life, please dispose of it in an environmentally friendly way. Drain any fluids (if applicable) into approved containers and in accordance with local waste regulations.
- Remove doors before disposal to prevent any person or animal being trapped inside.
- Check local, regional and national regulations for appropriate waste disposal instructions.

• **TROUBLESHOOTING**

Fault	Checks	Solutions
No operation	Is power switched off Are breakers and fuses tripped or blown No electricity power cut	Switch on Open the door and checking whether the lamp is lit.
Abnormal noise	Is fridge stable. Does fridge touch the wall.	Adjusting fridge's adjustable feet. Pull away from wall.
Poor refrigerating efficiency	Hot food or overloading. Door closing. Is the fridge in direct sunlight or close to central heating. Is the fridge well ventilated. Check temperature settings	Allow food to cool and DO NOT overload compartments. Check the door closing times and seal. Move appliance to a cooler area. Clear vents to maintain good ventilation. Set the appropriate temperature.
Peculiar smell in fridge	Spoiled food. Fridge requires cleaning.	Remove offending articles. Clean fridge.

Environment Protection and Waste Protection and Electrical Equipment Regulations (WEEE)

Recycle unwanted packaging materials. When this product is no longer required, or has reached the end of its useful life, please dispose of it in an environmentally friendly way. Drain any fluids (if applicable) into approved containers, in accordance with local waste regulations. Under the Waste Batteries and Accumulators Regulations 2009. It is our policy to continually improve products and we reserve the right to alter data, specifications and parts without prior notice. No liability is accepted for incorrect use of this product. Guarantee is 12 months from purchase date, proof of which is required for any claim.



Jack Sealey Ltd t/a Baridi, Kempson Way, Suffolk Business Park, Bury St Edmunds, Suffolk, IP32 7AR UK
Jack Sealey (EU) Ltd t/a Baridi, Farney Street, Carrickmacross, Co. Monaghan, A81 PK68 Ireland
 Tel: 01284 757575 • Email: support@baridi.co.uk • Web: www.baridi.co.uk